

PRODUCT DATASHEET

SG200

WIRELESS MULTI-CRITERIA DETECTOR

The SG200 Wireless Multi Criteria detector is a fully intelligent device, compatible with all Argus Translator and Expander Modules. The sensor combines both smoke detection and thermal detection technologies which can be used separately or as a combined heat and smoke sensor for improved performance and reduced unwanted alarms. The patented chamber and double dust trap provides the chamber with additional protection from airborne contamination whilst the well proven adaptive radio signal processing algorithms ensure the highest levels of life safety and system reliability.



KEY FEATURES

- Patented design of optical chamber
- Combined heat and smoke sensing
- Internal algorithm processing optimises performance
- 3rd party approval to EN54-5, EN54-7, EN54-25 & CEA4021
- 5 year expected battery life
- Bi-directional wireless communication
- Utilises standard low cost lithium battery technology
- 5 year product warranty
- Rate of Rise or High Temperature mode of operation on the thermal channel
- Colour options available

TECHNICAL INFORMATION

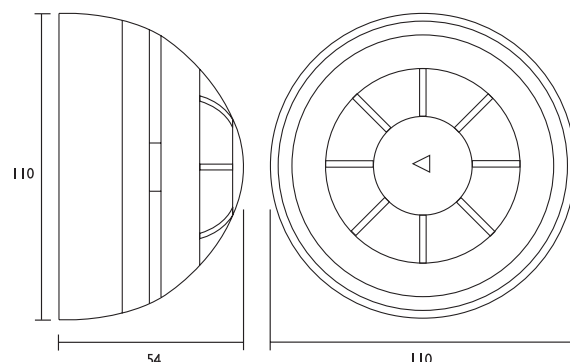

TECHNICAL SPECIFICATION

- | | |
|--|-------------------------|
| ■ Operating frequency range | 868 – 870 MHz |
| ■ Max radiated power | 5dBm (3mW) |
| ■ Radio signal modulation type | FSK |
| ■ Operating frequency channels | 7 |
| ■ Communication range with the Translator or Expander Module | ≤ 150 m (in open space) |
| ■ IP rating | 42 |
| ■ Dimensions | 110 mm x 54 mm |
| ■ Weight (without batteries) | 150g |
| ■ Primary battery | CR123A (3 V & 1.2 Ah) |
| ■ Secondary battery | CR2032A (3 V & 0.24 Ah) |
| ■ Primary battery lifespan (typical) | ≥ 5 years |
| ■ Secondary battery lifespan (typical) | ≥ 2 months |
| ■ Operating Temperature (no icing) | -10°C to +55°C |

STANDARDS & APPROVALS

- BS EN 54-5: Heat Detectors - Point Detectors
- EN54-7: Smoke Detectors - Point Detectors using scattered light, transmitted light or ionisation
- BS EN 54-25: Components using radio links and system requirements
- CEA4021: Requirement and test methods for multi-sensors



0832



928m

Note: Certified device performance may vary depending on the approval body.

PRODUCT DATASHEET : SG200

LED INDICATION

The device is equipped with a tri-colour LED (red/green/amber) that provides visual indication for functional conditions and battery levels as indicated in the sections below:

OPERATIONAL STATUS INDICATIONS

Status	Amber LED	Green LED	Red LED
Switching in to operating mode		Short flashes	-
Switching in to programming mode	-	-	4 short flashes
Self-adjustment mode	-	-	1 Second On & 0.1 Second Off
Normal condition	-	-	-
Alarm condition	-	-	0.5 Second On & 0.5 Second Off
Program failure	-	-	On Constantly
Main battery fault	-	-	0.1 Second On & 5 Seconds Off
Secondary battery fault	-	0.1 Second On & 5 Seconds Off	-
Both batteries fault	-	-	Sequential bi-colour flashing
Loss of radio link with Translator/ Expander	0.5 Second On & 2 Seconds Off	-	-

COMMUNICATION QUALITY ASSESSMENT

It is possible to assess the wireless communication quality between the device and translator or expander using the built in test facility. After successful programming of the device, changing the “Program” switch to the “ON” position will set the device into test mode and the LED will start blinking according to the table below:

Communication Quality (dB)	Level	Green LED	Red LED
No connection	Fail - 0 - No Connection	-	Two flashes
Link margin is less than 10 dB	Fail - 2 - Very Poor	-	One flash
Communication with link margin from 10 dB to 20 dB	Fail - 3 - Poor	One flash	
Robust communication with link margin over 20 dB	Pass - 4	Two flashes	

Note: The “program” switch must be returned to the 1 position for normal device operation